

**EXHAUST GAS FOR DIESEL ENGINES (EN 13190)
HEAVY DUTY EXECUTION, CLASS 1,0
WITH SILICONE OIL FILLING**

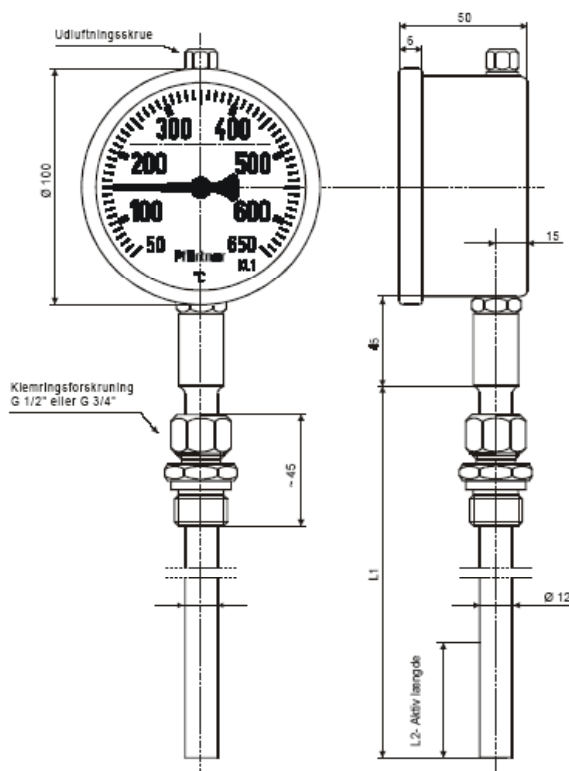

SPECIFICATIONS

TYPE NO.	:45.11, Vertical type
TYPE NO.	:45.21, Axial type
CASE	: $\varnothing 100$ mm. stainless steel AISI 304, sealed with rim-ring
PROCESS CONNECTION	:Adjustable compression fitting G 1/2" or G 3/4" , stainless steel AISI 316
RANGE	: +50...+650 $^{\circ}\text{C}$
ACCURACY	:Class 1,0. (EN 13190)
VIBRATION DAMPING	:Silicone oil
PROTECTION	:IP 65. (EN 60529)
STEM	:Standard lengths L1 : 160, 200, 250 and 300 mm. stainless steel AISI 316

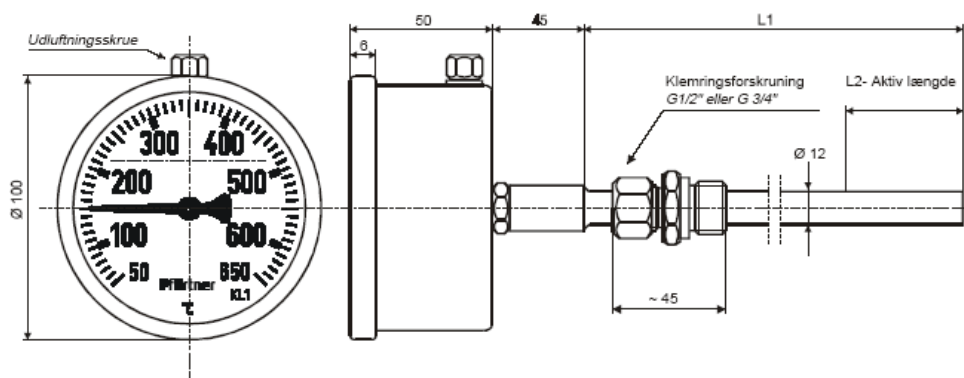

JØRN PEDERSEN A/S
måle- & reguleringsteknik

Bogøvej 18, DK-8382 Hinnerup, www.jp-industri.dk

Tel.: +45 86 98 66 22 Fax: +45 86 98 66 83 E-mail : info@jp-industri.dk